



**Intelligent 2-in-1 Electric Hob
(Infrared + Induction)**

智能2合1電能煮食爐

Model/型號：EC-2923

**Installation & Operating Instructions
產品使用說明書**

CONTENTS

1	Product Introduction-----	2
	1.1 .Introduction of Product	
	1.2 .Function & Characteristics	
2	Installation Guideline-----	3-5
3	Control Panel Instructions-----	6
4	Operation Method-----	7-9
	4.1 .Operation Instructions	
	4.2 .Usable and Non-usable Cookware	
	4.3. Heating Power Distribution	
5	Safety Precautions-----	10
	5.1 .Safety Notes	
	5.2 .Warning	
6	Daily Maintenance-----	11
7	Product Specification-----	11
8	Trouble-Shooting Guideline-----	12-13
	8.1 .Code Of Breakdown	
	8.2 .Trouble Shooting	

1 、 Product Introduction

1.1 、 Introduction Of Product :

Thank you for choosing **Garwoods 2-in-1 Electric Hob**. This product combines with two different calefaction principles. The left zone is infrared cooker and the right zone is induction cooker. It is controlled by the micro-computer touching sensor control system. Please read this operation manual carefully before installing or using this product.

1.2 、 Function & Characteristics :

- **Energy-efficient** : The electric hob utilizes the brand-new calefaction principle. For the part of the Infrared zone, it utilizes radiant heating element and the surface remains a residual heat for short-time cooking without power after cooking. It is energy-saving. For another part of the Induction zone, it is also both time-saving & energy-efficient because it directly heats up the bottom of the cookware and a heat transfer efficiency of up to 90% is achieved.
- **Multi-function** : The electric hob utilizes newest micro-computer chip program control. It offers multiple scales for heating power level regulation.
- **Safety & Environmental Friendly** : Safety & Environmental Friendly of the product is on our top priority. The electric hob contains a serious of safety system such as safety lock; high temperature indicator(Infrared part); overheat prevention(Induction part); cookware sensor (induction part) automatic shut-off when 2 hours not in use; and auto-temperature adjustment etc.
- **Easy-to-clean Surface** : Ceramic glass top panel is easy to clean. When the high temperature indicator is off and the surface is cool down after cooking, wipe it with a damp cloth.

【 Notice : The surface at infrared zone is under a very high temperature condition after cooking, please do not place any combustible materials on the surface and touch the surface to avoid any risk of fire and getting burnt 】
- **Touch Buttons Operation** : Touch button design is easy for use.
- **Intellectual Power** : The electric hob adopts intellectual power distribution technology and the specified power can be distributed to each cooker zone by the micro-computer system.

2 、 Installation Guideline

★ Installation should be followed below requirements :

- 1 、 The walls on top of the working face and next to the installation of the electric hob must be heat-proof.
- 2 、 The laminated boards and adhesive used for installation must be heat-resistant.
- 3 、 For any installation method, the air under the electric hob and behind the cooking range should have enough space for cooling in order to ensure the safety of operating the electric hob.
- 4 、 Based on the prescribed dimensions, a square hole is opened on the work table. Ensure the distance between any side of the work table and the walls is $\geq 100\text{mm}$.
- 5 、 Protect the opening: If in contact with damp, the laminated boards used in marking the work table will easily expand more. It is required to stick varnish or special adhesive onto the edge of the opening in order to prevent any steam from condensation under the work table.
- 6 、 For any condition of installation, the electric hob should have a good ventilation condition with air inlet and air outlet not blocked.
- 7 、 Don't place other equipments on the working face of the double cooking zones of the electric hob and within the range of 30cm around the working face.
- 8 、 If choosing a table-top installation, ventilation hole shall be at least 100mm from wall surface.
- 9 、 The electric hob must be complied with a 13A power outlet.

★ Steps on Installation :

~ Open an installation hole on the worktop of cabinet as per 【illustration 1】 .
(Note : The height shall be more than 100mm)

Cut out dimensions(unit/mm) : (W) 670 x (D) 350 x (H) 100

【illustration 1】

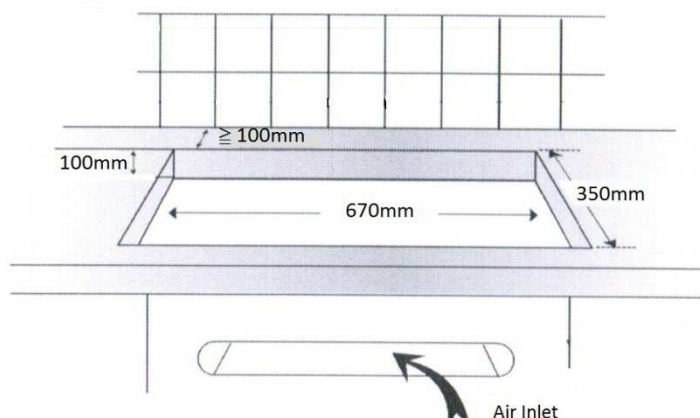

* If the installation hole on the work table is a new open, it is recommended a depth to 370mm and put the electric cooker into the hole at front side so as to have a good ventilation condition.

~ In front of the cabinet, open an air inlet with more than 100cm² under the location of the electric hob as per【illustration II】. If the cabinet is not sealed, the air inlet may not be opened so as to ensure heat elimination.

【illustration II】

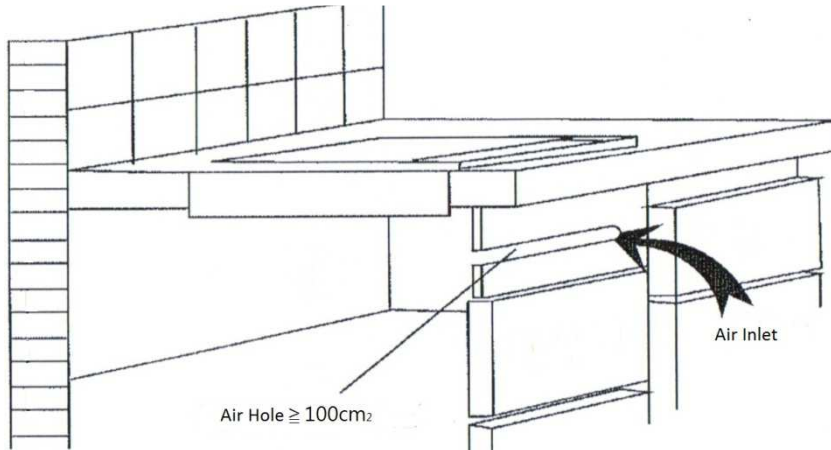

~ Before put the electric hob into the hole, an water-proof type is properly applied on the bottom of front panel of the electric hob as per 【illustration III】 . If the old size of the hole is large than the current size of cutting hole, a double side type can be used to fix the movement between the electric hob and worktop.

【illustration III】

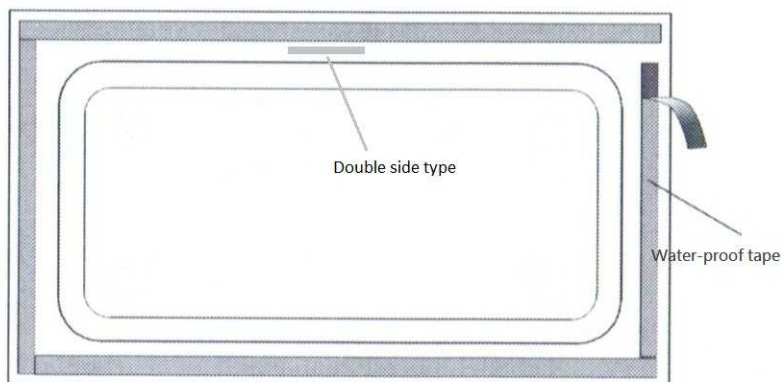

~ Put the electric hob into hole. Insert plug of power line into corresponding socket. The electric hob can be used after power connection as per 【illustration IV】 .

【illustration IV】

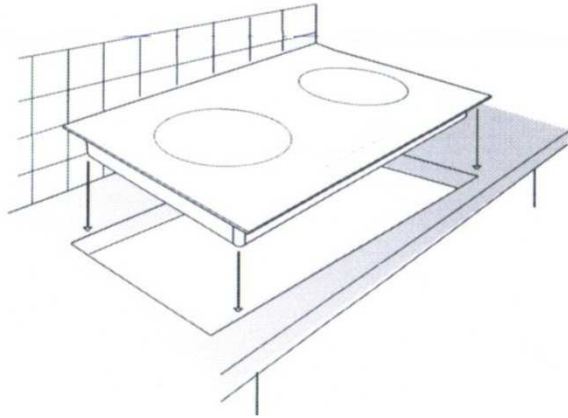

~ If the electric hob is installed above an oven, fix an insulation part at least 150mm under the electric hob as per 【illustration V】 . Also, open an air inlet with more than 100cm² under the location of the electric hob to ensure ventilation and operation in good conditions

【illustration V】

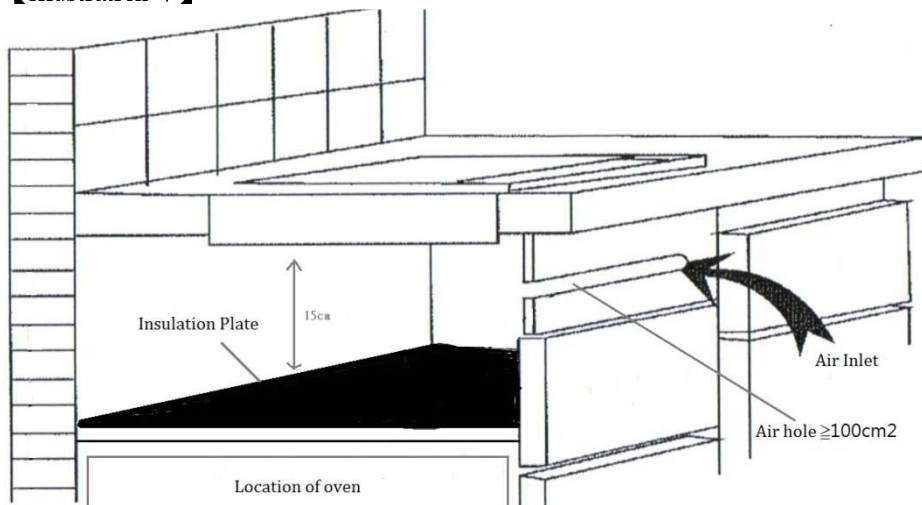

3、Control Panel Instruction

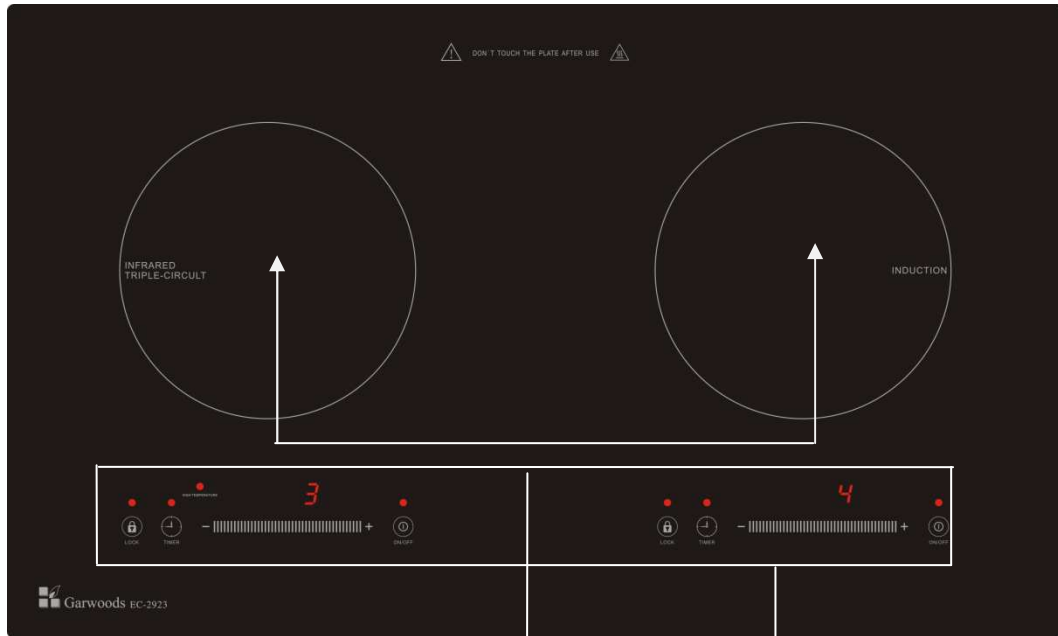

【Cooking Zone】

【Control Panel】

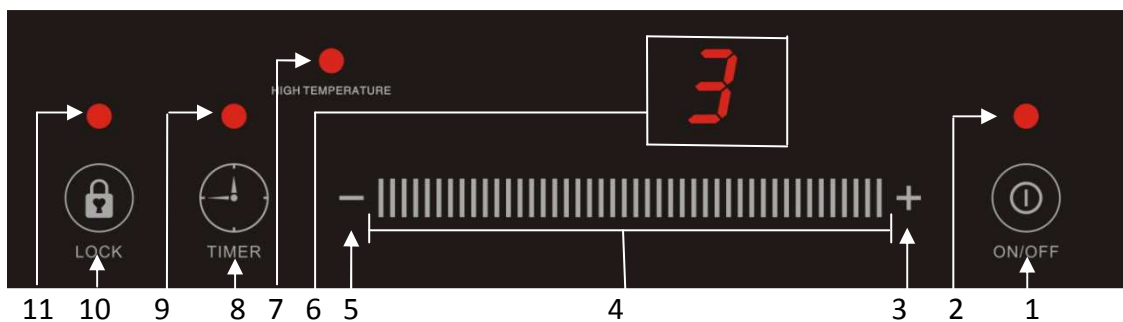

- | | |
|----------------------------------|--------------------------------|
| 11...Lock Indicator | 2...On/Off Indicator |
| 10...Lock Key | 3...Plus Key –Timer |
| 9...Time Indicator | 4...touchSlider bar – Power |
| 8...Timer Key | 5...Minus Key – Timer |
| 7...High Temperature Indicator | 6...LED Digital Indicator |
| (Apply for Infrared Cooker Only) | 7...High Temperature Indicator |
| | 8...Timer Key |
| | 9...Time Indicator |
| | 10...Lock Key |
| | 11...Lock Indicator |

4 、 Operation Method

4.1 、 Operation Instructions :

- **Power Connection** : After power connection, buzzer will make a short sound and the electric hob keeps at the stand-by mode. LED digit will show (- - -).
- **On switching** : Place cookware on heating zone (Pls. refer to Usable and Non-usable Cookware), by pressing the “ON/OFF” key, buzzer will make a short sound and the on/off indicator will be on. LED digit will show the pre-set power level “4”.
- **Power Level Alteration** : At the power function, touch the sliderbar from left to right side to increase the power level or decrease the power level from right to left side. LED digit shows set power level.

(Note : This electric hob adopts intellectual power distribution technology. When the power level of a cooking zone is increased and total power level exceeds specified value, the micro-computer system will automatically decrease power level of another cooking zone so as to assure total power is under specified value.)

- **Selecting Timer** : By pressing “Timer” key, the time indicator will be on. At the time, by pressing “+” Or “-” key to set the required time. The operational setting range is between 1 min. and 3 hrs 59 min. (Display form in 《hrs : mins》) After setting, the LED will show the required time. When set time is reached, buzzer will make a long sound and the electric hob stops heating. To cancel time setting, by pressing “Timer” key , then the time indicator will be off.
- **Lock Function** : By pressing the “Lock” key, buzzer will make a short sound and a red dot will be on. At this time, all keys will be locked in order to avoid mis-operation. By pressing “Lock” key 3 min. again, buzzer will make a short sound and a red dot will be off.

The electric hob will be locked automatically after 15 seconds when switching off. For restarting the electric hob, by pressing the “Lock” key 3 min. again, buzzer will make a short sound and the red dot will be off, then by pressing the “ON/OFF” key to enter the normal cooking mode by other function keys.

- **High Temperature Indicator** : After cooking, the “High temperature indicator” will be on and flicker, that means the temperature on the heating zone is over 70^oc. At this time, the heating zone is under a very high temperature condition, please do not attempt to place any combustible materials on the heating zone and touch the heating zone to avoid any risk of fire and getting burnt.
- **Off Switching** : During heating, by pressing “ON/OFF” key to switch off.

4.2 、 Usable and Non-usable Cookware :

1. Please refer to below information to select a suitable cookware cater for all delicious cuisine by the **infrared cooker**.

- Most of materials for a flat bottom cookware are suitable for use of the infrared cooker, such as stainless steel pot, iron pot, aluminum pot, ceramic pot and glass pot etc. The diameter of the flat bottom cookware is within 12-24 cm. For a good effect, it is recommended for an around 22 cm in diameter and depends on the thickness of the cookware at the flat bottom.
- It is normal that feeling hot from the heating zone if the flat bottom cookware does not cover the circle on the heating zone because it will release far infrared rays when cooking.

2. Please refer to below information to select a suitable cookware cater for all delicious cuisine by the **induction cooker**.

Usable Cookware	Non-usable Cookware
【 Materials 】 Iron, cast iron, stainless steel and enamel cookware.	【 Materials 】 Cookware made of pottery, aluminum, glass, copper or bronze.
【 Shape and size 】 The diameter more than 120mm (4.5 inches) are recommended.	【 Shape and size 】 The bottom diameter of the cookware is less than 120mm (4.5 inches). And, the cookware with curved bottom, with concave bottom (the concave depth \geq 4mm) or with legs (the height \geq 4mm).
【 Sorts of suitable cookware 】 Stainless steel kettle, iron tray, bottom pan, iron pot, iron tray, enamel pot etc.	【 Sorts of un-suitable cookware 】 Copper, bronze and aluminum pot, glass pot, pottery pot, bronze pan etc.

- It is normal that sound “ze..ze..” from the cookware when heating.

3. The cookware is placed in the center of the circle at the heating zone.

4.3 、 Heating Power Distribution :

When two single zones are operating in the same time, the total power level is up to 7. However, the power of one single zone will reduce automatically when the other zone is being cooking so as to maintain the total power level will not exceed 7.

Infrared Zone		Induction Zone	
Level	Power	Level	Power
7	2300W	0	0W
6	2000W	1	600W
5	1700W	2	1000W
4	1400W	3	1400W
3	1100W	4	1600W
2	800W	5	1800W
1	400W	6	2200W
0	0W	7	2800W

5 、 Safety Precautions

5.1 Safety Notes :

- No other objects than cookware to be placed on the calefaction area.
- Do not insert any objects like iron wire etc. into the vent in order to prevent any electric shock.
- Do not put anything to block the air outlet ◦
- Do not heat up unopened tins of food on the heating zone as pressure will build up in the tin and it can explode, which in turn could result in injury and scalding or damage.
- Do not use the electric hob in a high temperature environment. Keep it far away from fire.
- Always keep children away from the electric hob.
- Keep a distance between the water supply and the electric hob, to prevent any electric shock and interference or malfunction on function of the electric hob.
- Water or lliquid on the control panel will affect interference or malfunction on function of the electric hob.

5.2 、 Warning :

- The electric hob must not be installed over any metal work top or electrical appliances such as dishwasher, oven, and fridge etc.
- Do not place metallic objects such as knives, forks, scoops or spoons on the electric hob, calefaction area in order to prevent any danger caused by high temperature
- The plate of the electric hob is hot after cooking; do not touch the heating area by hand until the high temperature indictor is off or the glass surface has cooled down.
- If power wire is broken, you must shut off the power supply immediately and contact our After Sales Service professional to change the broken wire. User does not allow repairing by yourself, otherwise the maintenance of the electric hob will be invalid.
- Do not smash the glass surface, switch off the electric hob when the glass surface is cracked.

6 、 Daily Maintenance

- Clean the electric hob only when it has cooled down.
- Do not put any tinder of acid or alkaline materials near the electric hob in order to avoid the electric circuits inside the stove from the erosive damages of acidity and alkali which can affect the life span of the electric hob.
- Never use a steam cleaner or aggressive or abrasive detergent to clean the electric hob.
- Do not wash the electric hob directly with water.
- When cleaning the ceramic surface, wipe all coarse soiling off using a damp soft cloth and apply a few drops of proprietary-cleaning agent for ceramic surfaces.
- Do not let the bottom of the electric hob rubs the glass surface of the working area so as to prevent lacerating. (The laceration of the glass surface of the working area does not affect the normal operation of the electric hob).
- The air inlet should be cleaned regularly in order to have a good ventilation condition.
- Be sure to remove stains from the bottom of cookware. Otherwise, the stains will be scorched and stuck on the top plate.

7 、 Product Specification

Description	Intelligent 2-in-1 Electric Hob
Model	EC-2923
Power Supply	AC220-240V/50Hz
Total Rated Power	2800W
Overall Dimension(W x D x H)	750 x 450 x 65 mm
Net Weight	10 Kg

8 、 Trouble-shooting Guideline

8.1 、 Code Of Breakdown :

In case of improper installation or use, abnormal power supply or breakdown of the electric hob, the LED digit on front panel will display code of breakdown.

Infrared Cooker:-

Code of breakdown	Root cause of breakdown
E4	Failure of heater temperature sensor
E5	High power voltage
E6	Low Power voltage

Induction Cooker:

Code of breakdown	Root cause of breakdown
E0	Failure of Circuit
E1	Cookware not be sensed on the cooking zone
E2	High temperature inside induction heater
E3	Failure of heater temperature sensor
E4	Failure of IGBT temperature sensor
E5	High power voltage
E6	Low Power voltage

8.2 、 Trouble Shooting :

Garwoods's electric hob has adopted the most advanced micro-computer inspection and control technology. Some phenomena appeared in the course of working may not indicate problems to occur.

Please check the electric hob according to the follow specifications :

Situation	Reason	Solution
Infrared Cooker:-		
No power for the light indicators	The power cord may not be properly connected to power outlet	Check the power cord if it has been connected or not
Auto-power off during working of product	<ol style="list-style-type: none"> 1. The inlet of fan is off. 2. The fan stops working. 3. The surrounding temperature is too high. Pls. check if there is some heating device nearby. 4. The temperature of the stuff being heated rises too high. 5. Errors of timer setting 	<ol style="list-style-type: none"> 1. Clean and remove the stuff in the inlet of fan. 2. Ask help from a professional service technician. 3. Improve the ventilation. 4. Improve the ventilation. 5. Power off and re-start the product
Induction Cooker:-		
The heater works for a while and stop, indicating "E1"	<ol style="list-style-type: none"> 1. No cook ware put on the cooking zone 2. Non-usable cookware is used 	<ol style="list-style-type: none"> 1. Put the cookware on the cooking zone 2. Refer to "Usable and Non-usable cookware" in the operation manual
The heater works for a while and stops, indicating "E2" .	<ol style="list-style-type: none"> 1. The inlet of fan is off. 2. The fan stops working. 3. The surrounding temperature is too high. Pls. check if there is some heating device nearby. 4. The temperature of the stuff being heated rises too high. 5. The outlet ventilation is off. 	<ol style="list-style-type: none"> 1. Clean and remove the stuff in the inlet. 2. Ask help from a professional service technician. 3. Improve the ventilation. 4. Remove the cause for fry heating and continue to use the electric hob after the calefaction area is cooling down. 5. Inspect the outlet ventilation condition.
The heater works for a while and stop, indicating "E3" or "E4" .	The temperature sensor breakdown.	Ask help from a professional service technician.

目錄

一、產品簡介-----	15
I. 產品介紹	
II. 性能特點	
二、產品安裝說明-----	16-18
三、控制面板說明-----	19
四、產品操作說明-----	20-22
I. 操作說明	
II. 鍋具的選擇與使用	
III. 火力功率及功率分配說明	
五、使用注意事項-----	23
I. 安全注意事項	
II. 警告	
六、日常保養注意事項-----	24
七、產品規格-----	24
八、維修指南-----	25-26
I. 錯誤代碼	
II. 簡易故障的判別和排除	

一、產品簡介

I、產品介紹

多謝選購Garwoods 2合1電能煮食爐。本產品採用兩種不同加熱原理，左爐區為電陶爐及右爐區為電磁爐，由先進微電腦控制，輕觸式操作，安全耐用，適合各種不同的烹飪需求，是現代家庭廚房的理想之選。請在安裝及使用本產品之前閱讀本說明書。

II、性能特點

- **節能效益：** 本產品應用全新加熱原理。電陶爐部份採用紅外線加熱，高熱效率，節能環保。在使用烹調食物過程中，更可因應情況下截斷電源利用爐面產生餘下的高溫而作短暫烹煮，以達到節省燃料之效果。而電磁爐部份，同樣是節能環保。因為電磁爐直接傳熱至鍋具底部，而且熱效率高達90%。
- **齊全功能：** 本產品採用最新微電腦晶片程式操作，具有多段火力功率調節，方便實用。
- **環保安全：** 本產品在設計上充分考慮使用者的安全及環境保護。爐設有安全功能，如安全鎖、餘溫警告指示燈(電陶爐部份)、過熱保護裝置(電磁爐部份)、鍋具檢知功能(電磁爐部份)、2小時靜止操作及自動調溫功能等。
- **容易清潔：** 高級耐熱微晶玻璃面板、易潔耐用。烹調後，待餘溫警告指示燈熄滅及玻璃面板冷卻，才可進行清潔。

【注意：使用電陶烹煮後，面板仍處於高溫狀態，請勿放置任何易燃物件或接觸面板，以免造成火災及燙傷。】
- **輕觸式操作：** 輕觸式設計，只需要用手指輕輕觸摸玻璃控制面板上功能鍵即可，簡便易用。
- **智能功率：** 本產品採用智能功率分配技術。由微電腦根據用戶使用狀況，將規定的總功率分配到每個爐頭。

二、產品安裝說明

★安裝須遵守以下說明要求：

- 1、 工作枱面及靠近電能煮食爐的牆壁必須是耐熱的。
- 2、 用於安裝電能煮食爐與廚櫃的層板和膠黏劑必須是耐熱的。
- 3、 在任何安裝方式中，應確保爐具底下及爐面後側能徹底散熱，以確保安全。
- 4、 按規定尺寸在枱面上開一個安裝孔，同時確保任何一面距牆面距離至少100mm。
- 5、 安裝孔防水保護：若與濕氣接觸，製作廚櫃所用的層板相對容易膨脹，在開口邊緣塗上透明漆或專用膠黏劑，可防止水氣滲入造成蒸氣在廚櫃枱面下產生冷凝。
- 6、 在各種安裝條件下，電能煮食爐都需要良好的通風，要確保進氣口和出氣口不會被堵塞。
- 7、 電能煮食爐爐面四周及爐面垂直上方300mm的範圍內不要設置其它設備。
- 8、 如選擇座檯式安裝時，亦須確保排風口距離牆壁至少100mm。
- 9、 使用此型號電能煮食爐時必須配備**13**安培獨立開關掣或固定接線座。

★安裝步驟

1. 在需安裝電能煮食爐的廚櫃枱上按照【安裝圖 一】尺寸開一安裝孔
（注意：高度距離枱面需超過100mm）。

開孔尺寸(單位/mm)：(闊) 670 x (深) 350 x (高) 100

【安裝圖 一】

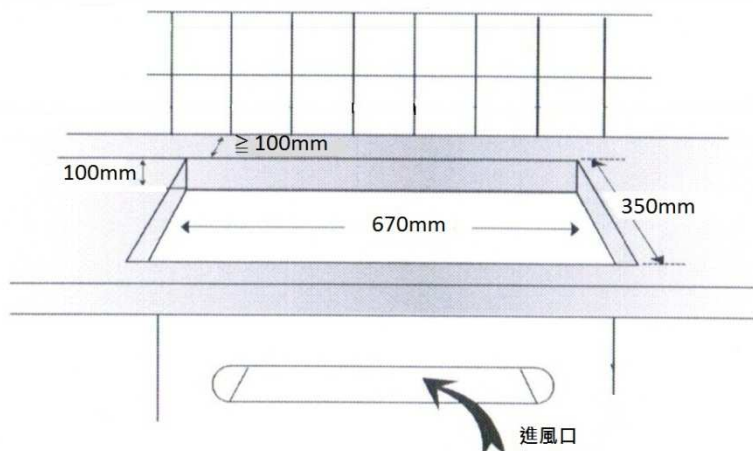

* 如屬新枱面開孔，開孔深度可開至370毫米，並將電能煮食爐緊貼枱面前方放進孔內以預留背部較多散熱空間。

2. 在櫥櫃前側電能煮食爐放位置的下方開出一個大於 100cm^2 的進風口如【安裝圖二】，以確保電能煮食爐有足夠的散熱，如果櫥櫃不是密封式的，可以不開此口，但電能煮食爐下方不可有任何雜物堵塞通風。

【安裝圖 二】

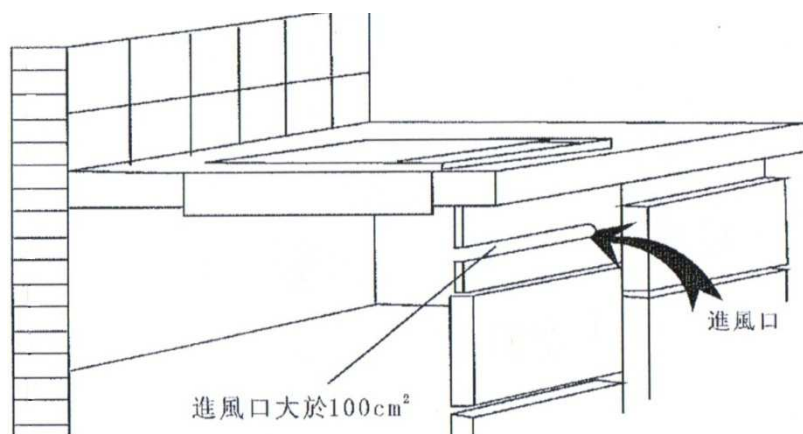

3. 安裝電能煮食爐在櫥櫃枱面前，必須將隨爐具所附的防水膠條如【安裝圖三】，貼在面板下方的四邊。如原枱面開孔大於本產品開孔尺寸，應使用雙面貼貼在底盤四邊，以固定爐具與枱面而避免產生移動。

【安裝圖 三】

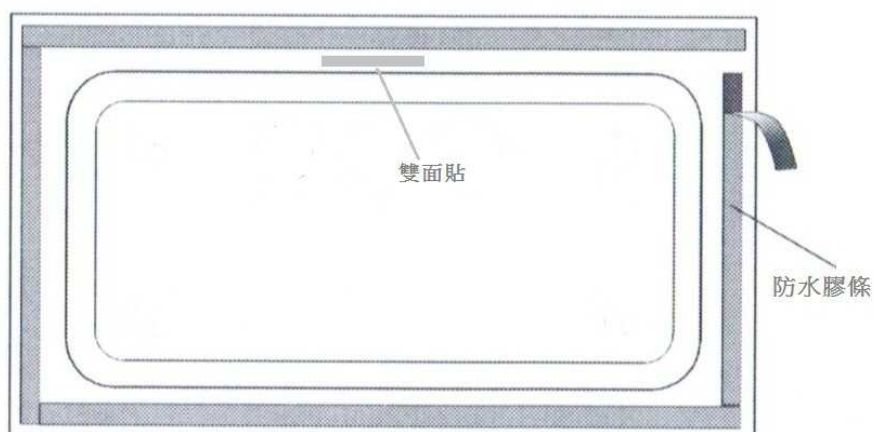

4. 將貼好防水膠條的電能煮食爐放入枱面開孔中如【安裝圖 四】，然後將電源線插頭插入對應的插座中，通電即可正常使用。

【安裝圖 四】

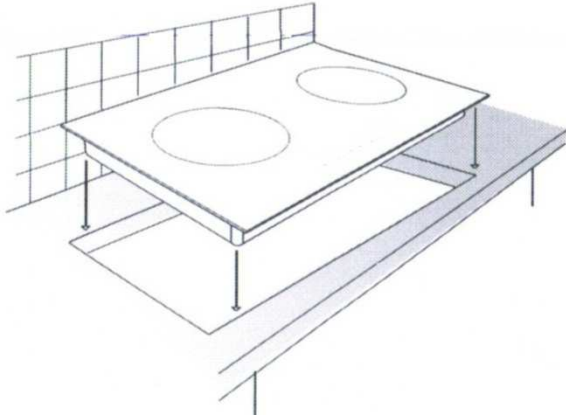

5. 如安裝電能煮食爐在烤箱上方時，櫥櫃內電能煮食爐與烤箱中必須加裝一個隔熱板如【安裝圖 五】隔熱板與電能煮食爐底部至少有150mm的距離：電能煮食爐安裝位置的前側必須開出一個大於100cm²的進風口以確保電能煮食爐與烤箱能夠有足夠的通風。

【安裝圖 五】

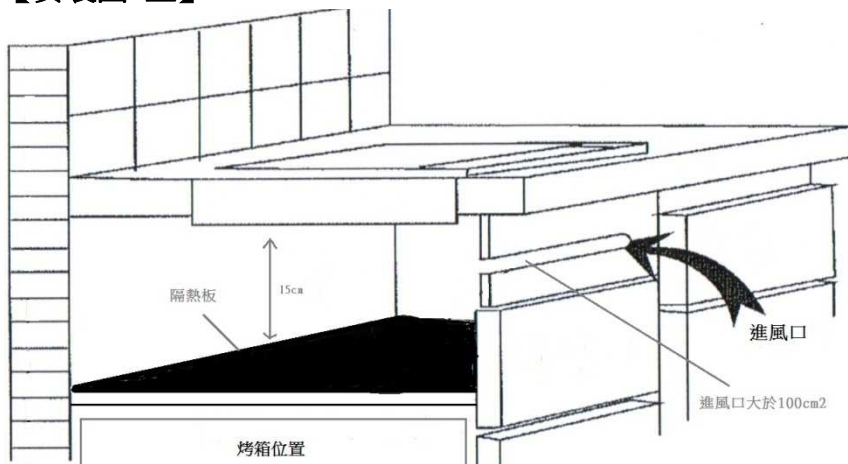

三、控制面板說明

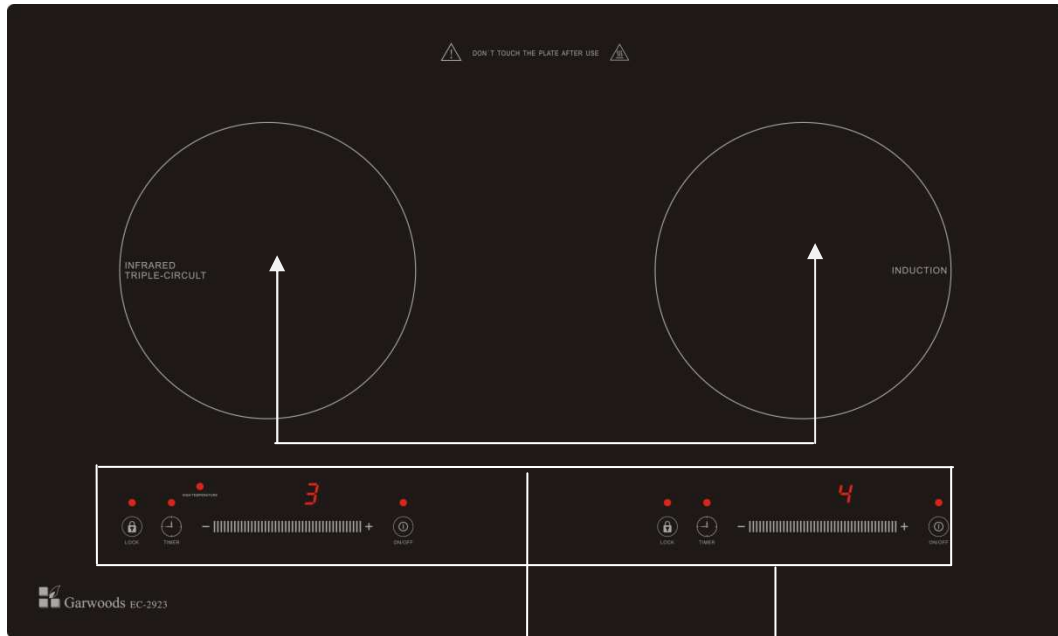

【加熱區】

【功能鍵】

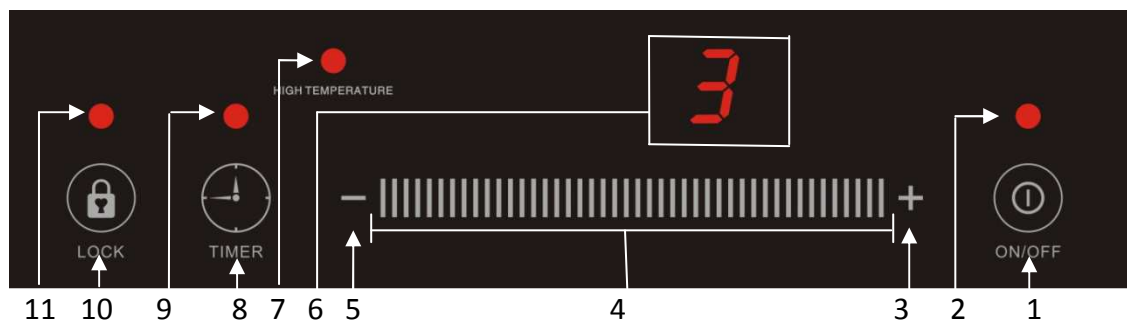

1…開關鍵

3…調高鍵 - (定時)

5…調低鍵 - (定時)

7…餘溫警告指示燈(只適用於電陶爐)

9…定時指示燈

11…安全鎖指示燈

2…開關指示燈

4…輕觸滑動操控條碼- (火力)

6…LED數碼顯示區

8…定時鍵

10…安全鎖鍵

四、產品操作說明

I、操作說明：

- **通電：** 電源接通後，蜂鳴器會發出一短聲，表示電源已接通，電能煮食爐處於待機狀態。LED數碼顯示會顯示為 (- - - -)。
- **開機：** 在加熱區放置所需的鍋具(請參考鍋具的選擇和使用)，按“開關鍵”，蜂鳴器會發出一短聲，開關指示燈會亮，LED數碼顯示會顯示為預設火力段數“4”。
- **調整火力：** 當火力功能運作時，輕觸滑動操控條碼可調高或調低火力段數，由左至右方向為“火力調高”或由右至左方向為“火力調低”，而LED數碼顯示區亦顯示所設定的火力段數。

(注意：本產品採用智能功率分配技術，當增加某一爐頭火力功率時，在總功率超過額定功率的狀況下，系統會自動降低另一爐頭的火力功率，以確保功率不會超過額定功率值)

- **設置定時：** 按“定時鍵”，定時指示燈會亮，然後按“+”或“-”置定所需要的定時時間。此時LED數碼顯示區內會顯示設定時間(顯示格式為《小時：分鐘》)，時間設定範圍為時間設定範圍為1分鐘至3小時59分。當達到所設定的時間時，蜂鳴器會發出一長聲，電能煮食爐會停止加熱。若要取消定時設定，只需按“定時鍵”，定時指示燈會熄滅。
- **鎖定：** 按住“鎖定鍵”，蜂鳴器會發出一短聲，同時鎖定指示燈會亮着，此時鎖定功能啟動，其它按鍵將會被鎖定而無法操作以防止兒童觸碰或其他意外觸碰操作。若取消鎖定功能，再次按住“鎖定鍵”3秒，蜂鳴器發出一短聲，鎖定指示燈熄滅，鎖定狀態被解除。

在關機狀態後15秒，電能煮食爐會自動上鎖，所有按鍵都不能操作。若需開啟電能煮食爐，先按“鎖定鍵”3秒，蜂鳴器會發出一短聲，鎖定指示燈熄滅，鎖定狀態被解除，然後按“開關鍵”，其他按鍵才可使用。

- **餘溫警告指示燈：** 使用電陶烹煮後，餘溫警告指示燈會亮着及閃爍，即表示加熱區爐面面板溫度達70°C時，切勿放置任何易燃物件或接觸面板，以免造成火災及燙傷。
- **關機：** 加熱過程中，按“開關鍵”即可關機。

II、鍋具的選擇與使用：

1. 配合**電陶爐**煮食，應參考下列好好選擇與使用適合的鍋具。
 - 電陶爐適用於各種材質的平底鍋具，包括不銹鋼、鐵、鋁、銅、耐熱玻璃、陶瓷及紫砂鍋等。而底部直徑必須在12-24厘米範圍內。若要達到最佳烹調效果，建議鍋具底部直徑約22厘米左右及底部厚度不要太厚。
 - 在煮食過程中，因電陶爐加熱區會釋放紅外線而產生高熱效率，若鍋具底部直徑未能覆蓋加熱區，將會感受有些微熱力，這情況下是屬於正常現象。
2. 配合**電磁爐**煮食，亦應參考下列好好選擇與使用適合的鍋具。

適合的鍋具	不適合的鍋具
【物料】 鐵或導磁不鏽鋼底的鍋具，最好選用註明「適合電磁爐煮食」的鍋具。	【物料】 以非鐵金屬(如鋁、銅)、陶瓷、耐熱玻璃等物料為鍋底的鍋具。
【形狀】 底部直徑必須在12-26cm範圍的平底鍋，鍋具重量連同盛載食物每邊不可起過20kg。	【形狀】 底部凹凸差距過大(凹陷深度大於4mm)、弧形鍋底、鍋底腳座高高於或等於4mm或底部直徑不超過120mm的鍋具。
【適合鍋具種類】 不銹鋼壺、鐵板、平底鍋、鐵鍋、鐵製烤盤及換糖磁鐵鍋等	【不適合鍋具種類】 鋁鍋、玻璃鍋、陶瓷鍋及銅鍋等

- 在加熱過程中，鍋具發出“滋、滋”的聲音，這情況下是屬於正常現象，因不同鍋具工作時振動頻率不同而產生電磁聲，這對使用者不會造成任何安全害
3. 除使用適合的鍋具、鍋具亦需放置在面板上加熱區的中央位置。

III、火力段數及功率分配說明：

兩邊爐頭同一時間運作時，兩邊火力段數之和最高為7，當一邊火力段數增大，另一邊火力段數將自動下調，以保持火力段數之和不超過7。

電陶爐		電磁爐	
段數	火力功率	段數	火力功率
7	2300W	0	0W
6	2000W	1	600W
5	1700W	2	1000W
4	1400W	3	1400W
3	1100W	4	1600W
2	800W	5	1800W
1	400W	6	2200W
0	0W	7	2800W

五、使用注意事項

I、安全注意事項

- 電能煮食爐上不要放置除加熱鍋具外的任何物體。
- 排氣口與吸氣口請勿插入鐵絲等異物，以避免發生觸電危險。
- 切勿堵塞排氣口。
- 請勿加熱沒有開封的罐頭類產品，因氣壓內積聚並會引起爆炸；導致身體受損或傷害。
- 請勿將爐具擺放在高溫環境中使用，並且這遠離火源。
- 時刻讓小朋友遠離電能煮食爐。
- 水源與電能煮食爐必須保持距離，以避免發生觸電危險及水份滲入電能煮食爐而產生功能上的干擾或故障。
- 水或類似液體留在電能煮食爐控制區域或附近表面，會令電能煮食爐產生功能上的干擾或故障。

II、警告

- 禁止將電能煮食爐擺放在鐵製檯面或家用電器上工作(如鐵製廚櫃、消毒碗櫃、雪櫃、焗爐、洗碗碟機等)。
- 爐具工作時請勿將金屬物件，如刀、叉、勺、蓋等物件放在上面，防止被意外加熱。
- 爐具使用後，因受加熱鍋具高溫影響，加熱區留有餘溫頗高，當餘溫警告指示燈亮着及閃爍，即表示加熱區爐面面板溫度達70°C時，切勿放置任何易燃物件或接觸面板，直至玻璃面板冷卻，以免造成火災及燙傷。
- 電能煮食爐出現異常情況，如電源線破損等，須由代理商或被授權的維修專業人員進行更換維修。用戶不得自行更換拆卸，否則不予保修(如產生任何安全事故，本公司概不負責)。
- 如陶瓷玻璃面板破裂，請立即關機，拔掉電源插頭以防觸電。須由代理商或被授權的維修專業人員進行更換維修。

六、日常保養注意事項

- 清洗電能煮食爐玻璃面板前，玻璃面板應先完全冷卻。
- 爐具周圍請勿放置任何易燃、酸性或鹼性物品，以免酸、鹼對電能煮食爐中的電路板受腐蝕而影響電能煮食爐的壽命。
- 禁止使用蒸汽、腐蝕性或磨砂的清潔劑來清洗電能煮食爐。
- 請勿用水直接沖洗機體。
- 陶瓷玻璃面板的清潔：陶瓷玻璃面板髒污的時候，用布沾水輕輕擦拭，如擦不掉時用稀釋中性去污粉或清潔劑清潔後，再用濕布擦拭即可。
- 請勿用有機溶劑或含苯等化學藥品擦拭電能煮食爐，以免產生化學作用。切勿使用硬刷子刷洗爐面，使用鍋具底部時不要摩擦工作區的陶瓷玻璃面板表面，以免造成面板刮傷（工作區陶瓷玻璃面板表面刮傷不影響電能煮食爐的使用）。
- 定期清理進風口污漬與灰塵。
- 請確保移除器皿底部污漬。否則，污漬會燒焦然後附在面板上。

七、產品規格

產品	智能2合1電能煮食爐
型號	EC-2923
適用電源	AC220-240伏特/50赫茲
總輸出火力功率	2800瓦
爐身尺寸(闊 x 深 x 高)	750 x 450 x 65毫米
淨重量	10千克

八、維修指南

I、錯誤代碼

當電能煮食爐安裝或使用不當、供電不正常或出現故障時，面板上的LED數碼顯示燈將顯示錯誤代碼。

電陶爐：

錯誤代碼	錯誤原因
E4	爐面溫度感測器失效
E5	供電電壓過高
E6	供電電壓過低

電磁爐：

錯誤代碼	錯誤原因
E0	電路故障
E1	鍋具未能感應
E2	機內溫度過高
E3	爐面溫度感測器失效
E4	IGBT溫度感測器失效
E5	供電電壓過高
E6	供電電壓過低

II、簡易故障的判別和排除

由於本產品採用了最先進的微電腦檢測控制技術，所以在爐具工作中出現的一些現象並不意味有故障，請先按以下說明檢查。

現象	可能原因	解決方式
電陶爐：		
指示燈不着	電源未正確地接駁或接觸不良	驗查電源插頭是否已正確地接駁電源插座及是否有鬆脫情況
自動停機	<ol style="list-style-type: none"> 1. 風扇進風口被塞堵。 2. 風扇停轉 3. 安裝使用環境溫度過高 4. 散熱位置被堵塞 5. 定時設定錯誤 	<ol style="list-style-type: none"> 1. 清潔、去除進風口堵塞物 2. 由專業維修人員修理 3. 改善環境條件 4. 改善環境條件 5. 關機及重新設定
電磁爐：		
電磁爐不工作，指示“E1”。	<ol style="list-style-type: none"> 1. 沒有鍋具放置至煮食爐區。 2. 使用不適用鍋具。 	<ol style="list-style-type: none"> 1. 放置合適鍋具。 2. 參考本說明書內「鍋具的選擇與使用」。
電磁爐工作一段時間，停機不工作，指示“E2”。	<ol style="list-style-type: none"> 1. 電磁爐風扇進風口被堵。 2. 電磁爐風扇停轉 3. 電磁爐使用環境溫度過高，檢查一下周圍有否發熱器具 4. 被加熱物體溫升過高 5. 電磁爐排風口被堵。 	<ol style="list-style-type: none"> 1. 清潔、去除進風口堵塞物 2. 由專業維修人員修理 3. 改善環境條件 4. 消除幹燒等原因，待電磁爐加熱區表面冷卻後可繼續啟動工作 5. 檢查排風口有否被堵。
電磁爐不工作，指示“E3” “E4”。	溫度感測器故障	由專業維修人員修理

Sole Agent : Araytron Technology Limited
總代理 : 千中科技有限公司
Enquiry/查詢熱線 : + 852 2397 3066 Fax/傳真 : + 852 2397 3055
Website/網址 : www.garwoods.com.hk